

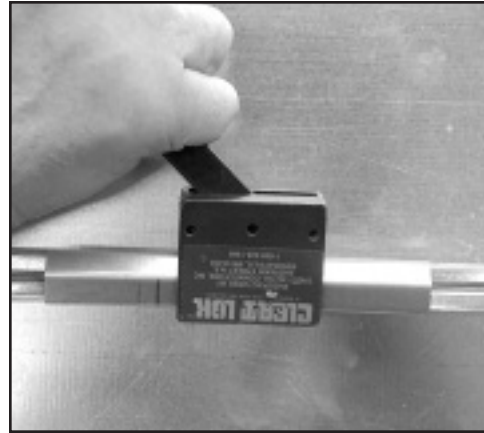

A "PIERCING" TOOL FOR TDC CLEATS



Cleat-Lok™ quickly and easily rolls TDC cleat onto duct joint.



Cleat-Lok™ handle can be pushed or pulled to complete "piercing" action.

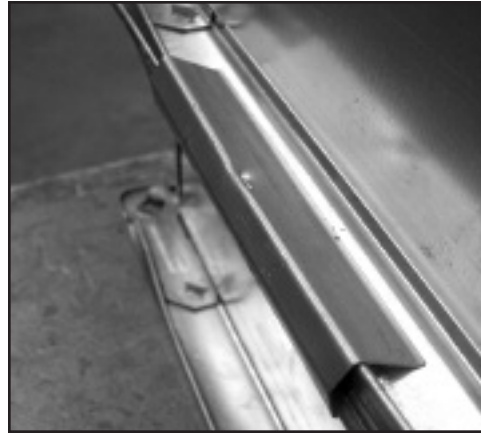

One "pierce" (except for 18 gauge where two are recommended) is all that is needed to provide a positive lock of cleat to duct.

TDC™ ACCESSORIES "Breakaway" Cleats

Price Information

Contractors can now avoid cost of fabrication and/or costly cutting charges with SMC's new, economical "breakaway" style TDC cleat. Cleats are included with each 30" length of 22 gauge galvanized metal. Check catalog for pricing.

1-9 Cleat-Lok™ Tools..... \$50.00 each
10 or more Cleat-Lok™ Tools..... \$40.00 each



SHEET METAL CONNECTORS, INC.

MINNEAPOLIS, MN

5850 Main Street N.E.

Minneapolis, Minnesota 55432

LOCALLY CALL: 763-572-0000

TOLL FREE: 1-800-328-1966

FAX: 763-572-1100

www.smcduct.com

ROCKFORD, IL

5601 Sandy Hollow Road

Rockford, Illinois 61109

LOCALLY CALL: 815-874-4600

TOLL FREE: 1-866-504-4600

FAX: 815-874-9979



Submittal Sheet

TDC

TRANSVERSE DUCT CONNECTOR SYSTEM

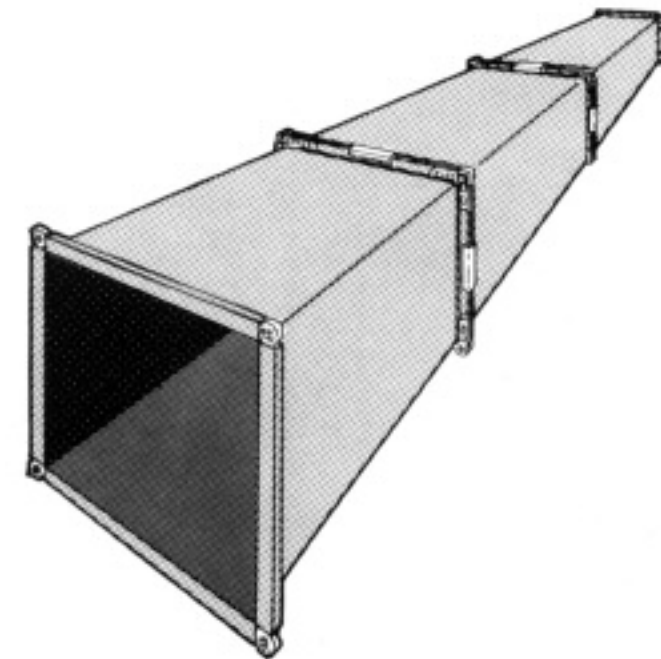

ASSEMBLY INSTRUCTIONS

TYPICAL CORNER ASSEMBLY SEQUENCE

1

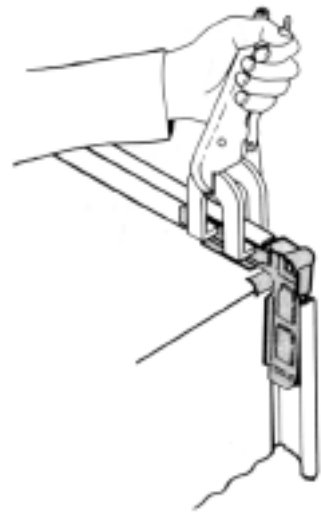

To install the corner, use Vice Grip #9 Toggle Action clamps or TDC corner crimper, as shown to snap one leg of the corner into place on the duct flange.

2

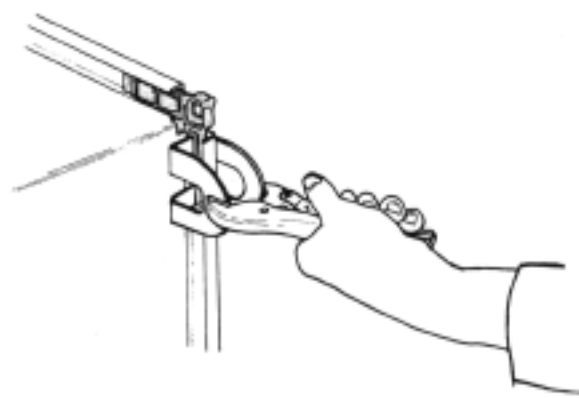

Snap the other leg of the corner into place. Install these at all four corners.

These corners may also be installed by setting the duct up on its end so the TDC flanges are flat against a floor, and then tapping the corners into place with a hammer. The floor supports the flanges, preventing damage by this procedure.

3

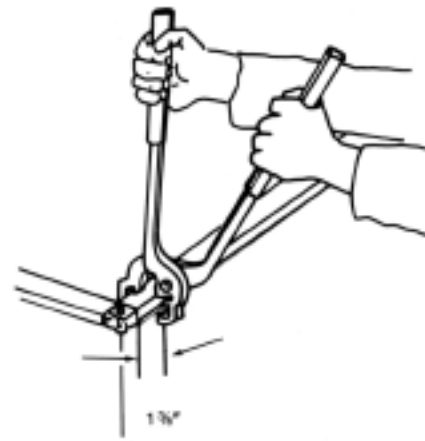

Hand Crimper (optional)
Place Hand Crimper jaws over flange as shown. Push movable arm until it hits stop. Crimp the flange in two places over both legs of each corner. Make first crimp while holding crimper with the side of its jaw aligned to the end of the flange. To make second crimp, position the crimper 1 3/8" from end of flange.

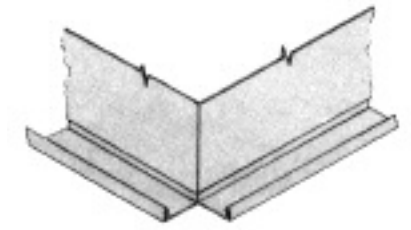

TDC Flange

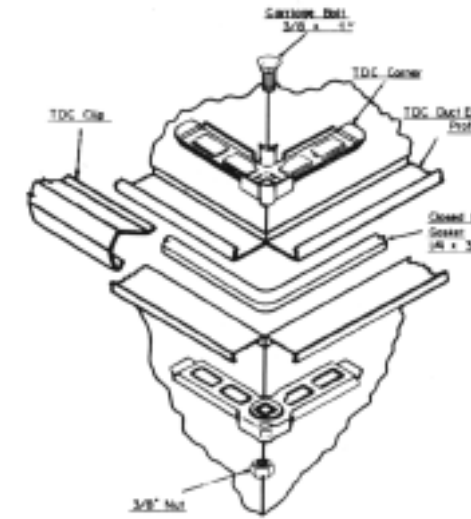
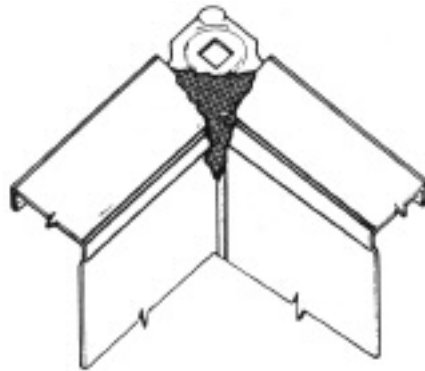

Chart #1
Corner
Assembly

4



Apply Sealant Tape over the corner as shown. Make sealant tape surface flush with surfaces of duct flange.

5

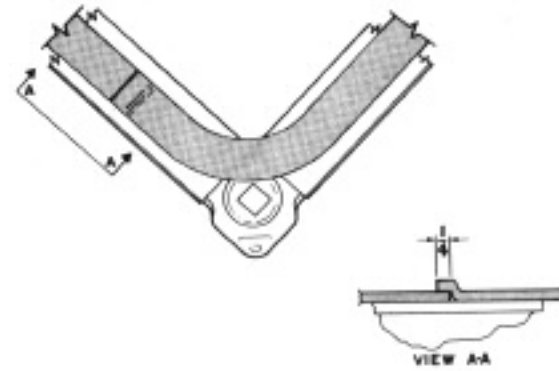

Place a single length of gasket on center of flange width along all four sides of one of the duct sections to be joined. Turn gasket at corners so it just touches bolt hole. The ends of the strip of gasket must overlap by 1/4" at a point at least 6" away from the bolt hole. A clip must be placed on the overlap (see Chart #2 for correct clip locations).

Recommended Gasket Material:
Pressure Sensitive, Closed Cell
15 lb. density, 1/4" thick x 3/4" wide.

6

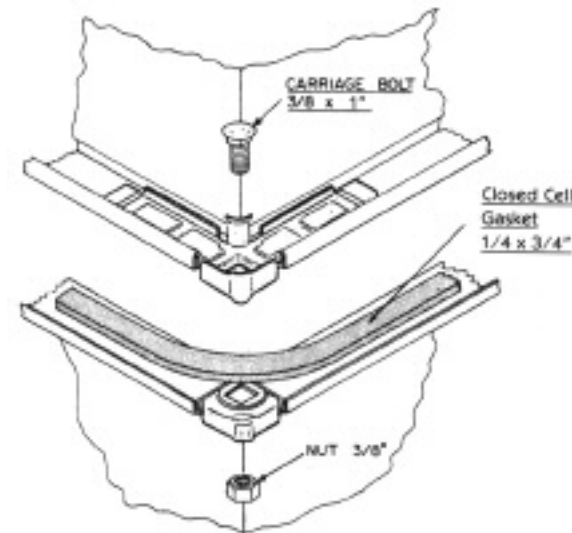

Place two prepared ends of duct sections together, align the bolt holes and secure with 3/8" x 1" long carriage bolts at all four corners.

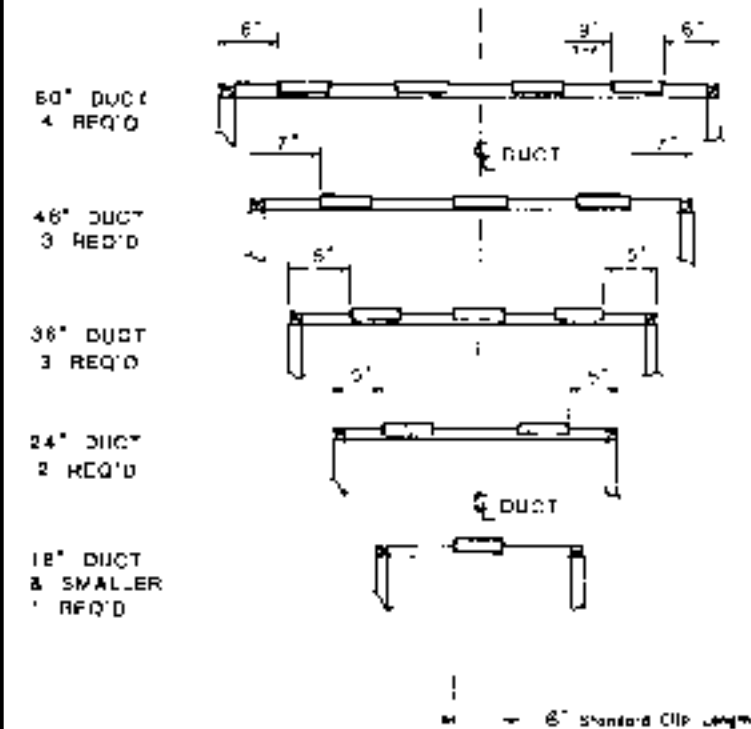

Recommended Clip Space
Chart #2