



# SHEET METAL CONNECTORS, INC.

[www.smduct.com](http://www.smduct.com)

**MINNEAPOLIS, MN**  
 5850 Main Street N.E.  
 Minneapolis, Minnesota 55432  
 LOCALLY CALL: 763-572-0000  
 TOLL FREE: 1-800-328-1966  
 FAX: 763-572-1100

**ROCKFORD, IL**  
 5601 Sandy Hollow Road  
 Rockford, Illinois 61109  
 LOCALLY CALL: 815-874-4600  
 TOLL FREE: 1-866-504-4600  
 FAX: 815-874-9979



## High Efficiency Takeoffs (H.E.T.O)

Our High-Efficiency Takeoff is designed with a rectangular opening and an approximate 45° slope on the body. A flange is turned out on all four sides with each corner being filled. The flange also has pre-punched holes for easy installation. There is a closed cell neoprene gasket (3/4" X 1/4") applied to the flange to assure a tight seal.

High-Efficiency Takeoffs are fabricated from both 26 and 24 gauge galvanized steel. The fittings come with and without volume dampers. The adjustable dampers are assembled using a spring loaded retractable bearing and positive locking hardware. Test data is available; call factory for more information. (Performed by ETL Testing Laboratories.)

### High Efficiency Takeoffs

Order as follows: A = Diameter  
 Also available with 2" Insulation Extension

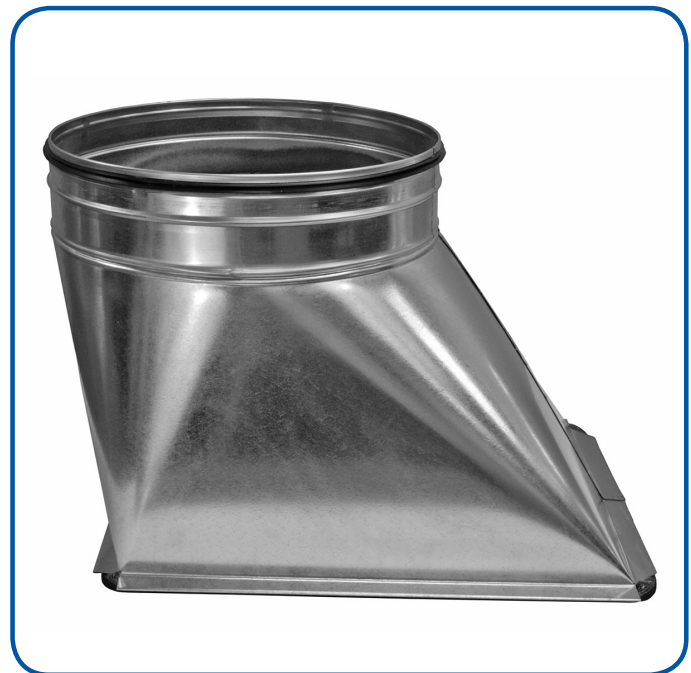
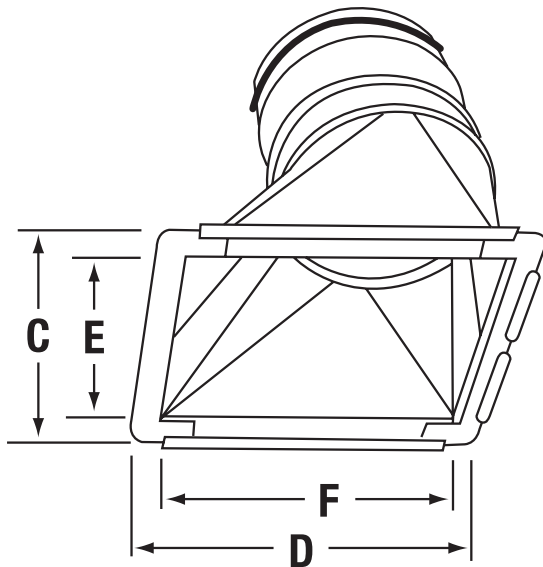

Hole Cut Size					
A	B	C	D	E	F
16"	13 1/2"	18"	22"	16"	20"
18"	13 1/2"	20"	24"	18"	22"
20"	13 1/2"	22 1/2"	26"	20"	24"
22"	17"	24"	28"	22"	26"
24"	17"	26"	30"	24"	28"

