



SHEET METAL CONNECTORS, INC.

www.smduct.com

MINNEAPOLIS, MN
 5850 Main Street N.E.
 Minneapolis, Minnesota 55432
 LOCALLY CALL: 763-572-0000
 TOLL FREE: 1-800-328-1966
 FAX: 763-572-1100

ROCKFORD, IL
 5601 Sandy Hollow Road
 Rockford, Illinois 61109
 LOCALLY CALL: 815-874-4600
 TOLL FREE: 1-866-504-4600
 FAX: 815-874-9979



Pants

Sheet Metal Connectors, Inc. manufactures rectangular fittings in most sizes and configurations. Fittings are manufactured on our state of the art fabrication equipment. All fittings are fabricated with stiffening beads on duct sizes 19" wide and larger which have more than 10 square feet of unbraced panel. Fittings shall be beaded unless duct will have an insulation covering or an acoustical liner. This requirement is applicable to 20 gauge or less in thickness and 3" W.G. or less. Most all fittings are fabricated with Pittsburgh seams. Fittings are available completely assembled with all accessories (reinforcement, vane & rail, etc...) installed. Fittings are also available knocked down to reduce shipping and handling costs.

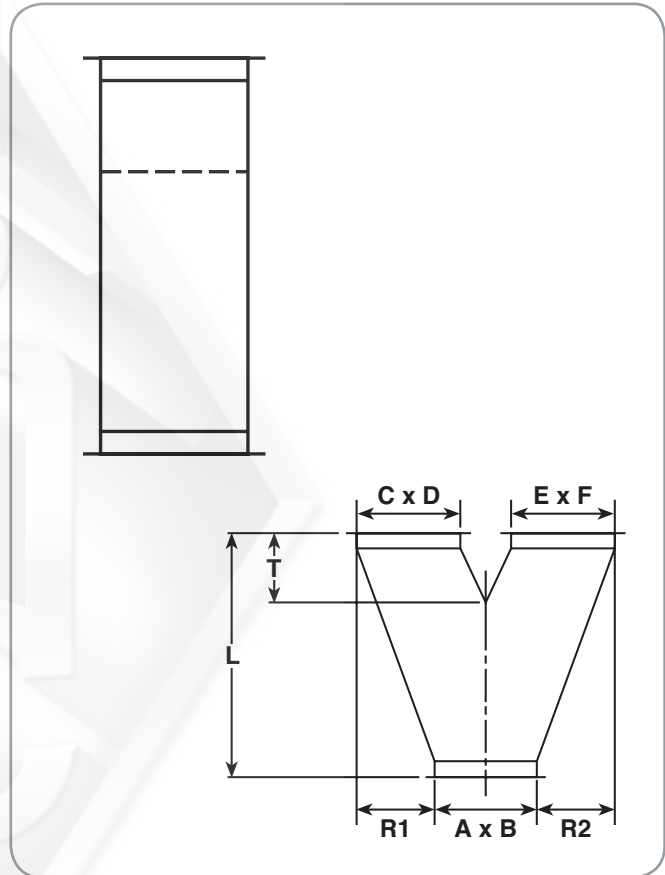

TDC Ductwork and Fittings

SMACNA recommended TDC™ duct is a 4-bolt system with a difference. Instead of cutting, assembling and installing a separate flange onto the ductwork, the TDC flange is roll formed directly onto the duct. This provides a solid metal connection that reduces leakage which is why the TDC system is the best for minimum leakage application. A TDC assembly instruction manual is available upon request.

MATERIAL	THICKNESS	ASTM	TYPE	DUCT	END TREATMENT
Galvanized	26 - 18 gauge	A-653	G60-G90	44 1/2", 56 1/2", 68 1/2"	TDC
Paint Grip	24 - 18 gauge	A-653	A60	56 1/2"	
PVS	24 - 18 gauge	A-653	4 x 1, 4 x 4	56 1/2"	
Aluminum	.032 - .050	B-316	3003 H-14	44 1/2"	
Stainless Steel	24 - 20 gauge	A-240	304 or 316	44 1/2"	

*Check with factory for availability of 68 1/2" in 26 gauge galvanized

Slip and Drive Ductwork and Fittings

Slip and drive ductwork is the traditional system using s-slip and drive connectors.

MATERIAL	THICKNESS	ASTM	TYPE	DUCT	END TREATMENT
Galvanized	26 - 18 gauge	A-653	G60-G90	47", 59", 71"	Slip and Drive
Paint Grip	24 - 18 gauge	A-653	A60	59"	
PVS	24 - 18 gauge	A-653	4 x 1, 4 x 4	59"	
Aluminum	.032 - .050	B-316	3003 H-14	47"	
Stainless Steel	24 - 20 gauge	A-240	304 or 316	47"	

*Check with factory for availability of 71" in 26 gauge galvanized

