



SHEET METAL CONNECTORS, INC.

MINNEAPOLIS, MN
5850 Main Street N.E.
Minneapolis, Minnesota 55432
LOCALLY CALL: 763-572-0000
TOLL FREE: 1-800-328-1966
FAX: 763-572-1100

www.smcduct.com

ROCKFORD, IL
5601 Sandy Hollow Road
Rockford, Illinois 61109
LOCALLY CALL: 815-874-4600
TOLL FREE: 1-866-504-4600
FAX: 815-874-9979



Submittal Sheet

Tie Rod Reinforcement

Sheet Metal Connectors Tie Rod Reinforcements are available Cut-To-Length. Manufactured using 1/2" electrical conduit (EMT) with 5/16" threaded inserts installed on each end. These Tie Rod Reinforcements are used for both mid panel and joint reinforcement. When using internal tie rods you may reduce the thickness of the duct wall. Always refer to SMACNA recommendations. Tie rods are also available in 3/4". Other lengths and diameters available, consult factory for prices.



Condu-Lock

Condu-Locks are threaded inserts that are installed into the ends of electrical conduit (EMT). They are available for both 1/2" and 3/4" EMT. Cut the conduit to duct size. Drive the Condu-Lock into each end using the installation tool. Then install into duct.

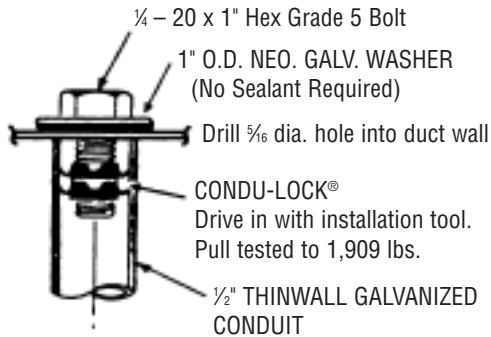

Quantity per Package	
1/2"	100 ea.
3/4"	100 ea.

EMT	
1/2" x 10'	Length
3/4" x 10'	Length

T-Lock ConduClamp

When tie rods occur in two directions in the same vicinity, they can be permanently fastened together using ConduClamp. ConduClamps are for both 1/2" and 3/4" EMT.

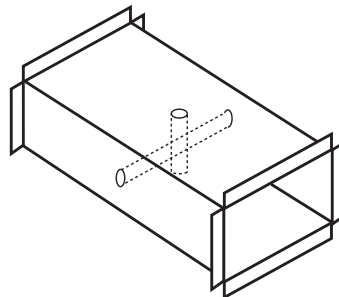

Size
1/2"
3/4"