



SHEET METAL CONNECTORS, INC.

www.smduct.com

MINNEAPOLIS, MN
 5850 Main Street N.E.
 Minneapolis, Minnesota 55432
 LOCALLY CALL: 763-572-0000
 TOLL FREE: 1-800-328-1966
 FAX: 763-572-1100

ROCKFORD, IL
 5601 Sandy Hollow Road
 Rockford, Illinois 61109
 LOCALLY CALL: 815-874-4600
 TOLL FREE: 1-866-504-4600
 FAX: 815-874-9979



Radius Offset

Sheet Metal Connectors, Inc. manufactures double wall fittings in most sizes and configurations. Double wall fittings are manufactured on our state of the art fabrication equipment. All double wall fittings are fabricated with stiffening beads on duct sizes 19" wide and larger which have more than 10 square feet of unbraced panel. This requirement is applicable to 20 gauge or less in thickness and 3" W.G. or less. Most double wall fittings are fabricated with Pittsburgh seams. Double wall fittings are completely assembled with all accessories (TDC corners, vane & rail, etc...) installed.

Double wall rectangular duct is constructed with TDC end treatments. There are two different types of applications:

- Acoustical double wall duct for noise control
- Thermal double wall duct for temperature control

Acoustical Double Wall

Standard acoustical double wall is for noise control. Constructed of a perforated inner shell surrounded by a layer of insulation and covered by a solid outer shell. The perforated inner shell has 3/32" diameter holes staggered at 3/16" on center for a clear open area of 23%.

Solid Outer Shell

MATERIAL	THICKNESS	ASTM	TYPE	DUCT	END TREATMENT
Galvanized	26 - 18 gauge	A-653	G60-G90	44 1/2" - 68 1/2"	TDC
Paint Grip	24 - 18 gauge	A-653	A60	56 1/2"	
PVS	24 - 18 gauge	A-653	4 x 1, 4 x 4	56 1/2"	
Aluminum	.032 - .050	B-316	3003 H-14	44 1/2"	
Stainless Steel	24 - 20 gauge	A-240	304 or 316	44 1/2"	

*Check with factory for availability of 68 1/2" in 26 gauge galvanized

Perforated Inner Shell

MATERIAL	THICKNESS	ASTM	TYPE	DUCT
Galvanized	24 - 22 gauge	A-653	G60-G90	TDC 56 1/2"

*Special order perforated available in other material - consult factory

Thermal Double Wall

Standard thermal double wall is for temperature control. Constructed of a solid shell surrounded by a layer of insulation and covered by a solid outer shell.

Solid Outer and Inner Shell

MATERIAL	THICKNESS	ASTM	TYPE	DUCT	END TREATMENT
Galvanized	26 - 18 gauge	A-653	G60-G90	44 1/2" - 68 1/2"	TDC
Paint Grip	24 - 18 gauge	A-653	A60	56 1/2"	
PVS	24 - 18 gauge	A-653	4 x 1, 4 x 4	56 1/2"	
Aluminum	.032 - .050	B-316	3003 H-14	44 1/2"	
Stainless Steel	24 - 20 gauge	A-240	304 or 316	44 1/2"	

*Check with factory for availability of 68 1/2" in 26 gauge galvanized

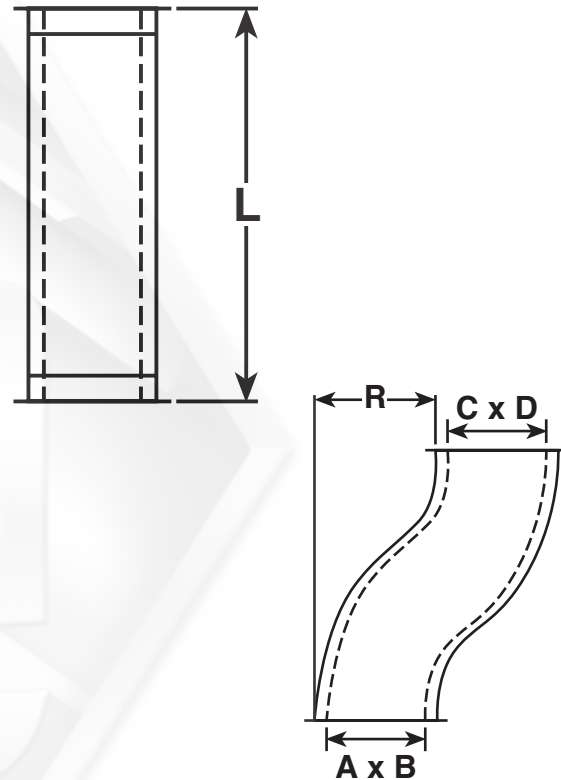

TDC Dimensions are I.D.

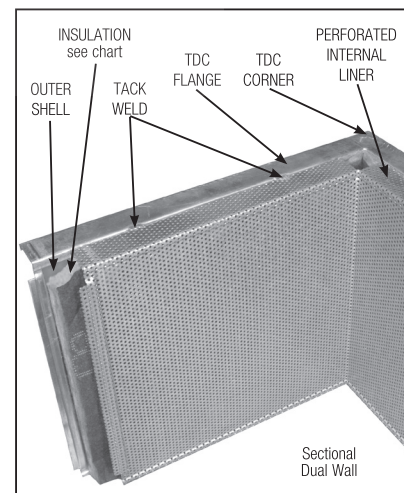

Sectional Dual Wall

